



# Analog Aerosol Photometer Model 2HA and 2HAN

## **Instruction Manual**



# Contents

---

## Sections

<b>Aerosol Photometer Overview.....</b>	<b>2</b>
Instrument Description .....	2
Filter Leak Testing: The Most Common Application .....	3
How the Photometer Operates.....	4
<b>Unpacking and Setting Up the Aerosol Photometer .....</b>	<b>5</b>
Unpacking .....	5
Installation .....	6
<b>Description of the Aerosol Photometer Controls and Indicators .....</b>	<b>8</b>
Front Panel Connectors and Indicators .....	8
Front Panel Controls .....	9
Rear Panel Connectors.....	10
Data Output.....	11
<b>Operating Instructions for the Aerosol Photometer.....</b>	<b>12</b>
Initialization.....	12
100% and Straylight Adjustment.....	12
Setting the Alarm Feature .....	13
Ready for Testing.....	13
The Internal Reference Feature.....	14
The Flowmeter Feature.....	15
<b>Maintaining and Servicing the Aerosol Photometer.....</b>	<b>16</b>
Maintenance.....	16
General Maintenance Procedures .....	16
<b>Specifications .....</b>	<b>18</b>
Specifications .....	18
<b>Accessory List.....</b>	<b>19</b>
Part Number List .....	19
Spare parts kits .....	19
<b>Contacting ATI.....</b>	<b>20</b>
For Technical or Application Questions .....	20
For Customer Service .....	20
<b>Declaration of Conformity.....</b>	<b>21</b>
<b>Warranty.....</b>	<b>22</b>
<b>Manual Revision History .....</b>	<b>23</b>

---

## Figures

Figure 1 Analog Aerosol Photometer, 2HA.....	2
Figure 2 Front Panel - Analog Aerosol Photometer, 2HA .....	8
Figure 3 Front Panel Controls - Analog Aerosol Photometer, 2HA.....	9
Figure 4 Rear Panel - Analog Aerosol Photometer, 2HA.....	10
Figure 5 Voltage Output - Analog Aerosol Photometer, 2HA.....	11

---

## Tables

Table 1 Packing List for the Analog Aerosol Photometer Model 2HA.....	5
Table 2 List of optional items for the Aerosol Photometer Model 2HA.....	5
Table 3 Specifications of the Analog Aerosol Photometer Model 2HA .....	18

(Intentionally Left Blank)

# Chapter 1

## Aerosol Photometer Overview

---

### Instrument Description

The 2HA is a forward light-scattering, linear photometer. The basic functions of the 2HA are to sample air or other gas and report the concentration of particulates in the sample.

This unit is also available in a nuclear version, the 2HAN. The nuclear version is the same size and has the same features as the 2HA, plus a sealed sampling chamber and a HEPA exhaust filter to contain all contamination within the unit.

The 2HA is compact and lightweight. The instrument case is constructed of die cast aluminum and has a swing arm carrying handle that folds up under the case to tilt the unit for easy viewing.



**Figure 1**  
Analog Aerosol Photometer, 2HA

---

## Filter Leak Testing: The Most Common Application

The most common application of the 2HA is to detect leaks in high efficiency filter systems (HEPA & ULPA). To establish the integrity of a filtration system, a challenge agent consisting of an airborne test aerosol is generated and introduced upstream of the filter. The challenge agent is used to provide enough particulate matter upstream of the filter to allow statistically valid measurements downstream of the filter.

The test aerosol should be introduced into the upstream side of the filter(s) as far from the filters as is practical to insure adequate mixing. 10 duct diameters are considered ideal. A sample of the aerosol-air mixture should be taken from the upstream side, close to the center of the filters. This sample is used to set the 100% base line since it is the concentration of the challenge aerosol. The apparatus is adjusted as described in the Operating Section to set the 100% reading and then the stray light is adjusted. The stray light adjustment is necessary to compensate for any signal caused by dark current or reflection of internal surfaces of the scattering chamber. After these adjustments have been made the equipment is ready to check leaks on the downstream side of the filters.

The filter test is performed with the use of the scanning probe. The filter and the perimeter of the filter pack should be scanned by passing the probe in slightly overlapping strokes so the entire area of the filter is sampled. The end of the probe should be held one inch from the filter surface. Separate passes should be made around the entire periphery of the filter, along the bond between the filter pack and the frame, and around the seal of the filter. Readings on the meter will indicate percent of penetration, and 0.01%, 0.1%, 1.0%, or 10% scales may be used as required.

The display indicates the percent of leakage through or around the filter. The scanning probe is supplied with 3 types of nozzles that can be attached to the end of the flexible probe. The round, black nozzle is 1 inch (25 mm) in diameter, which complies with NSF (National Sanitation Foundation) Standard 49-1992. The rectangular, blue isokinetic nozzle is used for faster scanning and is accepted by many standards, including NSF 49-2002. The round, red nozzle is also an isokinetic nozzle. The isokinetic nozzles are designed for face velocities of 90 +/- 20 feet per minute (fpm) when using a 1 cfm (28.3 L/min) sample rate.

---

## How the Photometer Operates

When air or gas is drawn through the scattering chamber, particulate matter in the sample passes through the focal point of the scattering chamber. Particulate matter scatters light into the dark cone and onto the photomultiplier tube, which converts the light into an electrical signal. The signal is then amplified and displayed on the analog meter on the front panel.

A photometer is ideally suited to detect particulate matter in air or gas, reporting the mass concentrations encountered on an analog display. Particles from less than 0.1 micron to approximately 600 microns can be detected by the 2HA. Since the photometer reports concentration of particulate matter (relatively independent of size, shape, or color), many applications are possible. By using a baseline of 100 micrograms per liter of aerosol, it is possible to directly read the concentrations of aerosol.

### Sampling System

A vacuum pump provides a sample flow rate of 1 cfm (28.3 liters per minute) for the instrument. It is an oil-free, dual head, rotary vane pump with a direct-coupled DC motor.

A selector valve on the front panel directs the airflow through the sampling system to the scattering chamber from three possible sources. The CLEAR position directs clean air from an internal ULPA filter to the scattering chamber for zeroing the instrument. The UPSTREAM position permits sampling of the aerosol above the filter being challenged, and the DOWNSTREAM position permits sampling of the aerosol that penetrates the filter.

### Light Scattering Chamber (LSC)

The scattering chamber is not only an integral part of the sampling system; it is a major component in itself. The scattering chamber is a complex electro-optical unit that consists of a pair of hollow cones connected at the apexes. A pair of collimating lenses first straightens the light emerging from the light source, and then focuses it at the center of the sampling cone. An aperture forms a dark cone around the photomultiplier tube, preventing light from arriving directly on the photomultiplier tube. A condensing lens opposite the LED source focuses light scattered into this dark cone onto the photomultiplier tube.

### Amplifier

The signal from the photomultiplier tube in the scattering chamber is delivered to an FET operational amplifier capable of a gain increase of 2,500,000. The amplifier augments the phototube signal in a linear fashion and is fed simultaneously to the front panel indicator meter, the remote scanning probe and the 0-1 VOLT DC output.

# Chapter 2

## Unpacking and Setting Up the Aerosol Photometer

### Unpacking

Carefully unpack and remove the 2HA Analog Aerosol Photometer and all accessories from its shipping container. If the instrument has been damaged in transit, notify the shipper immediately.

The Analog Aerosol Photometer 2HA consists of a photometer and accessories, including the following:

**Table 1**

Packing List for the Analog Aerosol Photometer Model 2HA

Qty.	Item	Part Number
1	Power Cord	6700001
1	12 feet of Clear PVC Tubing	5200116
1	Operating Manual	1800116
1	Calibration Certificate	N/A

The following items are optional. Check the order packing slip.

**Table 2**

List of optional items for the Aerosol Photometer Model 2HA

Item	Part Number
Shipping Case	9300102
Analog Scanning Probe	0200202
Round Isokinetic Nozzle (Red)	T2E0-0572
Rectangular Isokinetic Nozzle (Blue)	T2E0-0798
NSF 1" Round Nozzle (Black)	T2E0-0005

After unpacking, if anything is missing or appears to be damaged, contact ATI Customer Service at (410) 363-9696.



### Note

ATI recommends that you save all packing materials for future use, such as shipping the unit back for annual calibration.

---

# Installation

## Before you begin

You will need the following items to set up the Analog Aerosol Photometer Model 2HA:

- An electrical outlet (110 VAC or 230 VAC).
- ¼" ID plastic tubing (12 feet supplied) or optional scanning probe.

## Connecting Electrical Power

Voltage and current requirements for the Analog Aerosol Photometer Model 2HA are:

- 100 to 120 VAC, 5 amps, or
- 230 to 240 VAC, 2.5 amps

The Aerosol Photometer automatically adjusts to operate at the correct AC voltage for the destination country (given this voltage is within the specifications described in Appendix A). This voltage is noted on a label attached to the back panel of the instrument. The power cord contains a plug which is specifically adapted to the destination country.

You are responsible for plugging the power cord into a matching receptacle. To connect the Filter Tester to electrical power, do the following:

1. Check to make sure the Aerosol Photometer is turned off. (Refer to figure 4 for the location of the power switch.)
2. Plug the power cord into a matching power outlet.



### Note

Before connecting the power cord to the power outlet, make sure the cord has not been cut or otherwise damaged during shipment.



### Caution

To prevent damage to the Aerosol Photometer, make sure the voltage listed on the back panel matches the power outlet where you plug it in.

## Connecting the Sampling Line

The Analog Aerosol Photometer comes standard with 12 feet of ¼" ID Clear PVC or with an optional scanning probe.

Before you operate the unit, connect the appropriate sampling device to the unit according to the following instructions:

- If using the Aerosol Photometer with the standard clear PVC tubing: connect one end of the sampling hose to the barbed "DOWNSTREAM" port of the unit located on the front panel (Refer to figure 2 for the location of ports on the unit).
- If using the Aerosol Photometer with the optional scanning probe: connect the probe ¼" ID sampling hose to the barbed "DOWNSTREAM" port of the unit and connect the probe's electrical connector to the 12-pin connector on the front panel of the unit before applying the power to the unit (Refer to figure 2 for the location of the ports and scanning probe connector).



### Note

The unit is calibrated to sample 1 cfm through 12 feet of ¼" ID PVC tubing. Failure to use the specified length of tubing might result in inaccurate readings.

# Chapter 3

## Description of the Aerosol Photometer Controls and Indicators

### Front Panel Connectors and Indicators

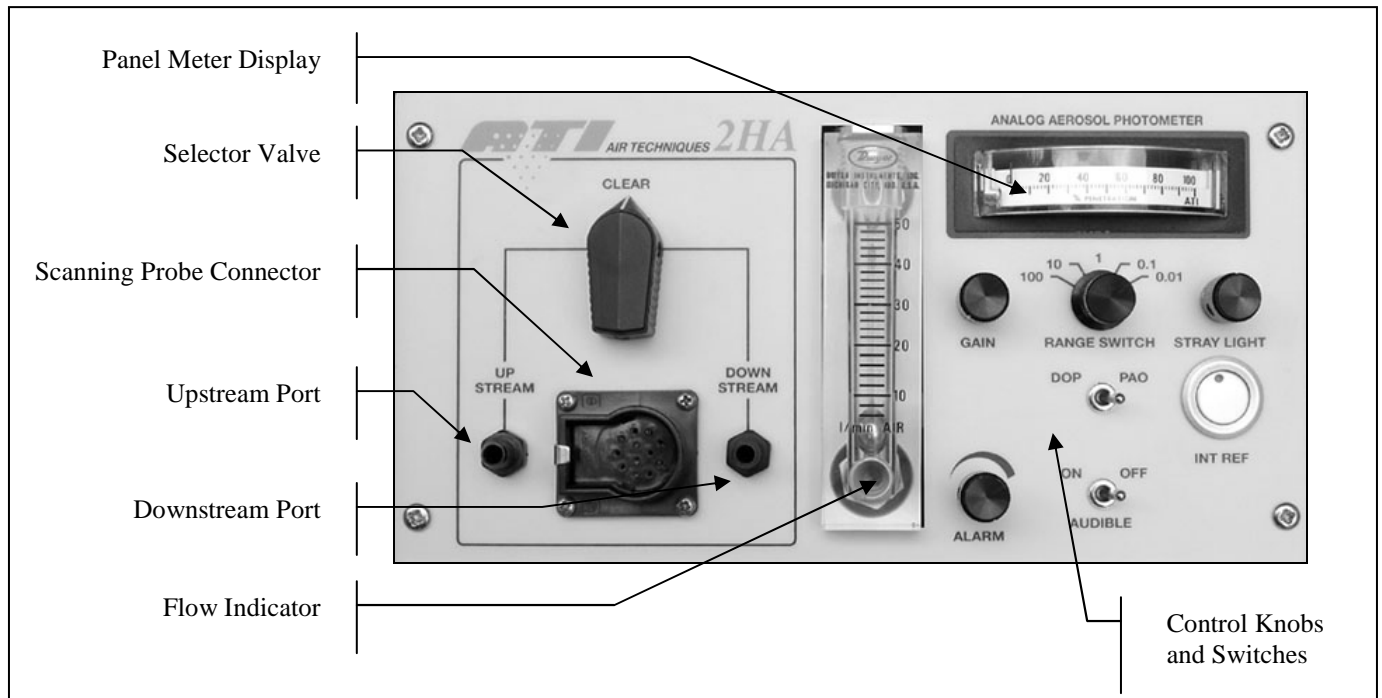

**Figure 2**  
Front Panel - Analog Aerosol Photometer, 2HA

- 1. Panel Meter Display** Displays the percent penetration.
- 2. Selector Valve** Selects the sample source.
- 3. Scanning Probe Connector** 12-pin electrical connector for the optional scanning probe.
- 4. Upstream Sample Port** Connects to the sample tubing or optional scanning probe that is used to measure the upstream aerosol concentration.
- 5. Downstream Sample Port** Connects to the sample tubing or optional scanning probe that is used to measure the downstream aerosol concentration.
- 6. Flow Indicator:** Displays the flow drawn through the scattering chamber in liters per minute.
- 7. Control knobs and switches** Used to set operating parameters.

# Front Panel Controls

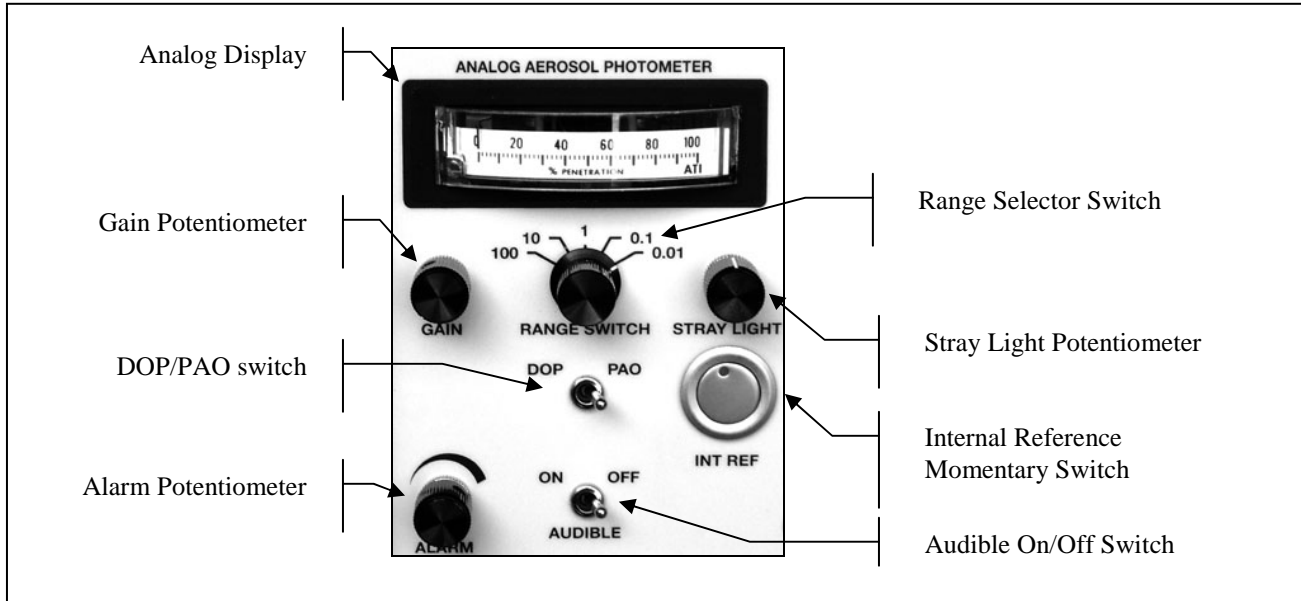

**Figure 3**  
Front Panel Controls - Analog Aerosol Photometer, 2HA

- |   |  |
|---|--|
| <ol style="list-style-type: none"> <li>1. <b>Analog Display:</b></li> <li>2. <b>Gain Potentiometer:</b></li> <li>3. <b>Stray Light Potentiometer:</b></li> <li>4. <b>Range Selector Switch:</b></li> <li>5. <b>DOP/PAO Switch:</b></li> <li>6. <b>Internal Reference Momentary Switch:</b></li> <li>7. <b>Audible On/Off Switch:</b></li> <li>8. <b>Alarm Potentiometer:</b></li> </ol> | <p>Shows the percent penetration.</p> <p>Allows adjustment of the control voltage to the photomultiplier tube, thus controlling the sensitivity of the unit.</p> <p>Compensates for reflected light inside the scattering chamber and dark current.</p> <p>Sets the gain of the solid-state amplifier.</p> <p>Determines the pre-set internal reference to be used as 100 micrograms per liter of aerosol reference (factory set).</p> <p>Activates the secondary light source to set the gain for a pre-set reference (DOP or PAO).</p> <p>Turns the audible alarm on or off.</p> <p>Allows the user to adjust the alarm set-point.</p> |
|---|--|



## Note

The optional scanning probe features an analog DC ammeter display on the pistol grip that is a duplicate of the front panel indicator. The two displays are driven by the same electronics and read the same value.

## Rear Panel Connectors

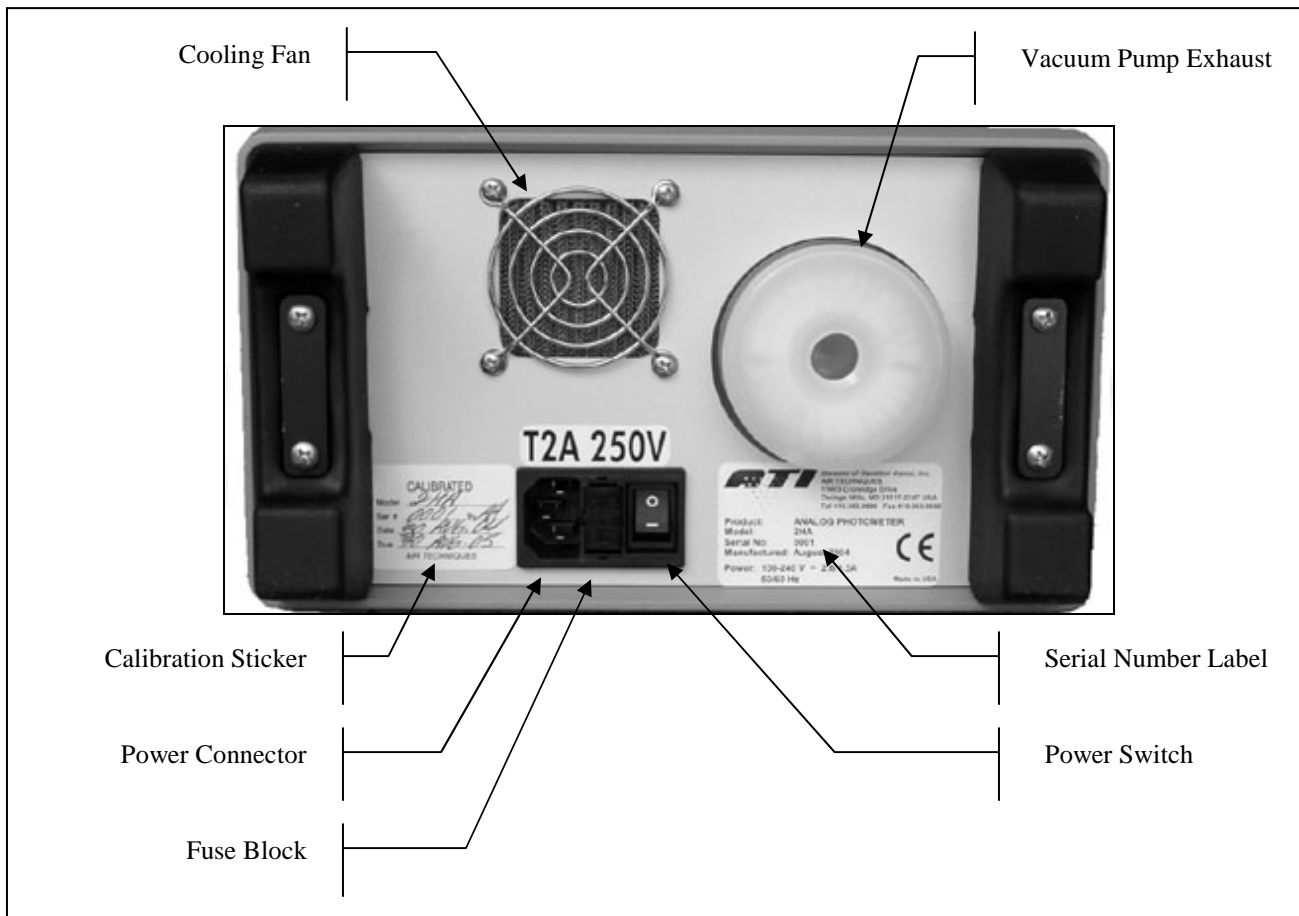

**Figure 4**

Rear Panel - Analog Aerosol Photometer, 2HA

1. **Cooling Fan:** Maintains airflow through the unit's enclosure to stabilize electronics.
2. **Calibration Sticker:** Displays the current calibration date and the due date for the next calibration
3. **Power Connector:** Connects to the Power Cord.
4. **Fuse Block:** Contains 2-amp fuse and spare fuse.
5. **Vacuum Pump Exhaust:** Allows a filter to be installed to eliminate particulate emissions.
6. **Serial Number Label:** Lists the model, serial number and utility requirements.
7. **Power Switch:** Turns the system power on and off.

---

## Data Output

The Analog Aerosol Photometer 2HA features a 0-1 Volt DC full-scale output located on the side of the unit in the form of a 9-pin female D-subminiature connector. This connector allows you to connect the unit to a data logging device.

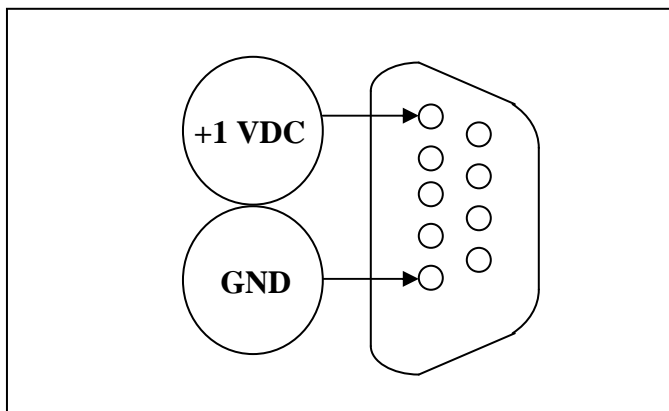

**Figure 5**  
Voltage Output - Analog Aerosol Photometer, 2HA

# Chapter 4

## Operating Instructions for the Aerosol Photometer

---

### Initialization

If the Scanning Probe is being used, connect it to the Scanning Probe Connector and the Downstream Port. Verify that the Selector Valve is in the CLEAR position. Apply power to the 2HA by setting the Power Switch to the 1 position (On). The analog display will move all the way to the 100 mark when the unit is turned on and will return to the zero position after a second.

---

### 100% and Straylight Adjustment



Turn selector switch to the least sensitive range or 100% position.

Note
The upstream sample line should be the same length (12 feet) as the downstream sample line or scanning probe.

Insert the **UPSTREAM** line into the aerosol air mixture being used for testing upstream of the filter. The sample should be drawn from the upstream side of the test duct, as close to the filter as possible (approximately 6" from the filter face).

Set selector valve to the **UPSTREAM** position. This changes the air route from the reference filter in the unit to the **UPSTREAM** sampling port on the front panel.

Adjust the **GAIN** control until a reading of 100 is obtained on the meter. This establishes the 100% baseline and provides a direct readout for the lower scales. Since this sample (100% reading) is drawn from the turbulent side of the filter system, the reading will usually vary. Averaging the reading on the indicator is recommended for proper **GAIN** adjustment. For example, if the reading varies from 60 to 100 on the meter, adjust the **GAIN** control for no lower than 80. This will still establish the 100% base for all downstream readings.

Set selector valve to the **CLEAR** position to provide clean, particulate free air for the scattering chamber.

Set selector switch to the 0.1% range.

Adjust the **STRAYLIGHT** control to obtain a reading of 0.0 on the meter. This adjustment compensates for an incidental light or electronic noise in the system and establishes the 0.000% base line.

Attach the downstream sample line or the optional scanning probe to the downstream port. Set the selector valve to the **DOWNSTREAM** position and start scanning the filter. A reading over 10 on this scale exceeds 0.01% penetration.



### Note

An ideal upstream aerosol concentration is between 10 and 100 micrograms per liter of airflow. Occasionally a situation occurs when the system being tested uses large volumes of air causing dilution of the aerosol. Should this be the case and a problem arises with respect to obtaining a 100 reading, then every effort should be made to introduce additional aerosol so that the 100 reading may be obtained.

---

## Setting the Alarm Feature

If the alarm feature is desired, adjust **STRAYLIGHT** control for a reading two increments below the point at which you wish the alarm to activate. Then turn the **AUDIBLE** switch to the **ON** position and slowly rotate the alarm adjustment knob clockwise until the alarm stops. Next readjust **STRAYLIGHT** control for zero. Whenever a reading exceeds your set point, the alarm will reactivate. You can deactivate the sound alarm by turning the **AUDIBLE** to the **OFF** position. Your settings will be kept and the red LED on the probe will still light on when the set point is exceeded.



### Note

For adjustment of a 0.01% alarm on the 0.1% scale, turn the selector switch to 0.1% and set the gain for a reading of 80 on the panel meter. Turn on the audible alarm switch and rotate the alarm adjustment knob clockwise until the audible alarm turns off.

---

## Ready for Testing

After the 100% baseline is established the unit is ready for use. Testing is performed as follows:

- The scanning probe may be used with both the meter on the panel and the meter on the probe.
- Set the **SELECTOR SWITCH** to the desired testing range.
- Turn the selector valve to the **DOWNSTREAM** position to permit sampling through the probe.
- Pass the nozzle of the scanning probe over the area being tested at a traverse rate of not more than 6 seconds per foot, 1" from the surface.
- Readings on the meter are directly in percent of penetration. If the penetration is too high to be read on the current scale then the **SELECTOR SWITCH** should be set to a the less sensitive scale as required to make the readings.

# The Internal Reference Feature

## Generalities

This instrument is equipped with an internal reference feature that permits a reference to a concentration equivalent to 100 micrograms per liter of aerosol. It is factory adjusted for two types of aerosol (PAO and DOP). Please note that the internal reference feature is to be used as a reference point only. It is not essential to the operation of the photometer. This feature allows the user to sample an unknown quantity of aerosol and get an instant readout in micrograms per liter of aerosol concentration. It also allows the user to adjust the photometer for a calculated GAIN level when access to the sample upstream challenge concentration is not possible.



### Note

When using the internal reference feature, always check the position of the DOP/PAO switch.

When the internal reference (INT REF) switch is depressed a secondary light source is activated. The activated light source is set so that a gain adjustment to 10% results in a 100% response to 100 micrograms per liter of aerosol. Lower concentrations will read accordingly.

## Example

If an upstream sample is taken and a reading of 75 on the 100% range is obtained, this indicates a 75 microgram per liter concentration. Suppose a sample of the ambient air is taken and a reading of 80 on the .1% range is obtained. This indicates an aerosol concentration of 0.08 micrograms per liter of ambient air.

If a filter's challenge concentration is known but a sample is unavailable to establish 100%, a calculated value may be obtained to allow the proper internal reference (INT REF) setting using the following formula:

$$\frac{100}{\text{Known Concentration}} \times 10 = \text{Proper INT REF}$$

Example:

Known Concentration = 20 micrograms per liter

$$\frac{100}{20} \times 10 = 50 \text{ Proper INT REF Setting}$$

Known Concentration = 125 micrograms per liter

$$\frac{100}{125} \times 10 = 8 \text{ Proper INT REF Setting}$$

In other words, we are increasing the **INT REF** setting as indicated by a higher **GAIN** to compensate for the lower concentration in the first example. Since we have only 20 micrograms instead of the usual 100 microgram concentration, we must increase the

**GAIN.** We only have 1/5 of the 100-microgram concentrations, so we must increase the INT REF setting by 5 times. Thus we increase the **INT REF** from 10 to 50 in the first example.

Conversely, in the second example, we are decreasing the **INT REF** setting to compensate for concentrations in excess of 100 micrograms per liter.

## Using the Internal Reference

- Set the valve to the **CLEAR** position.
- Set the selector switch to 10% position.
- Adjust the **STRAYLIGHT** control fully clockwise.
- Depress the **INT REF** switch.
- Adjust the **GAIN** control to obtain a meter reading of 100 plus or minus 2 in the 10.0% range.
- Release the **INT REF** switch.
- Turn the selector switch to testing position, 0.1% or 0.01% position.
- Adjust the **STRAYLIGHT** control until a reading of 0 is obtained on the meter.
- The unit is now ready to measure the upstream concentration (refer to “100% and Straylight Adjustment” section).

---

## The Flowmeter Feature

The Analog Aerosol Photometer Model 2HA comes standard with a Flowmeter indicator. This useful feature allows the user to ensure that the unit is operating at 1 cfm.

### Operation

In order to read the Flowmeter, place the unit on a horizontal surface and turn it on. You will then be able to read the value of the flow through the unit by proceeding as follows:

The standard technique for reading a Variable Area Flowmeter is to locate the highest point of greatest diameter on the float (middle of the ball), and then align that with the theoretical center of the scale graduation. In the event the float is not aligned with a graduation, an extrapolation of the float location must be made by the operator as to its location between the two closest grads.



### Note

While in operation the unit can be tilted in any direction and its functionality will not be affected. However, In order to accurately read the Flowmeter, the unit must be on a horizontal surface.

# Chapter 5

## Maintaining and Servicing the Aerosol Photometer

---

### Maintenance

#### Weekly

- Clean the scanning probe screens. These are located on the black and red circular scanning probe nozzles.
- Clean the gross particulate screen located at the base of the flexible scanning probe extension.
- Remove any loose debris from the Scanning Probe and front panel sampling ports.

#### Annually

- Return the 2HA to a factory authorized facility for calibration and cleaning. Please contact the ATI Customer Service Department at 410-363-9696 for a return authorization number. A service date will be scheduled for your instrument at that time.



Note
A Return Authorization can also be obtained using ATI's website or by sending an e-mail requesting service information to <a href="mailto:info@atitest.com">info@atitest.com</a> . A customer service representative will process your information and contact you with a Return Authorization, necessary instructions and information within 48 hours.

---

### General Maintenance Procedures

The 2HA Analog Aerosol Photometer is a sturdy, solid-state electronic instrument designed to hold up under extended field use. The only moving parts are the vacuum pump, the selector valve and the ventilating fan at the rear of the chassis. Field level maintenance is limited to replacement of the ULPA exhaust filter and the fuse. Procedures for these operations are contained in this section.



Note
The internal electronics are not user serviceable. Any electronic problems must be analyzed and repaired at an authorized service center.

There is no indicator on the front panel showing that the scattering chamber light source is not working. If the scattering chamber light source has burned out, the operator will witness a lack of response on the unit's display.

## Recommended Spare Parts

Spare components are not supplied with the 2HA or the 2HAN nuclear unit and must be ordered separately. See section A-2 for a list of recommended spare parts that may be purchased in kit form or individually. These lists include only parts replaceable by the user in the field. Other repairs requiring instrument or component recalibration must be performed at an ATI service center.

## Cleaning the Analog Scanning Probe Screens

The Analog Scanning Probe is a rugged, low maintenance device. The probe contains a coarse wire screen near the base of the flexible neck to prevent fibers and large particles from being drawn into the photometer. In addition, there are screens in each of the two round nozzles that thread onto the flexible neck. The blue rectangular nozzle contains no screen.

If the screens accumulate a significant amount of debris and become partially clogged, it will interfere with the airflow and affect the accuracy of the photometer and will put an unnecessary strain on the vacuum pump.



### Caution

It is recommended that all screens be wiped clean with a lint-free cloth before use each day.

If the screens are punctured, replace them immediately. Spare nozzles and replacement scanning probe components can be ordered from ATI (see Appendix B for the accessory list).

To access the screen in the flexible neck, unscrew the flexible extension from the probe body. A small tool may be necessary to reach into the neck to remove and wipe the surface of the screen.

# Appendix A

## Specifications

### Specifications

The following specifications—which are subject to change—describe the most important data regarding the Analog Aerosol Photometer 2HA.

**Table 3**

Specifications of the Analog Aerosol Photometer Model 2HA

<b>Dimensions (L x W x H)</b>	
<b>English (inches)</b>	10.1 x 14.3 x 5.8
<b>Metric (centimeters)</b>	25.7 x 36.3 x 14.7
<b>Weight</b>	
<b>2HA</b>	15.5 lbs (7.0 kg)
<b>2HAN</b>	15.5 lbs (7.0 kg)
<b>Scanning Probe</b>	2.5 lbs (1.1 kg)
<b>Input Power</b>	90 to 250 volts AC, 50 or 60 Hz, 1.5 amps
<b>Fuse</b>	250 volts, 2.0 amps slow blow (5 x 20 mm)
<b>Dynamic Range</b>	0.0001 to 100 micrograms per liter
<b>Accuracy</b>	2% of full scale for the amplifier decade in use
<b>Sampling rate</b>	1 cfm (28.3 L/min)
<b>Flowmeter Accuracy</b>	5% of full scale ( $\pm 2.12$ L)
<b>Data Output</b>	DB9 Connector providing a 0 to 1 VDC

Specifications are subject to change without notice.

# Appendix B

## Accessory List

### Part Number List

Part Number	Description
T2G0-1038	2HA Spare parts kit (see list below for components)
T2GN-0948	2HAN Spare parts kit (see list below for components)
9300102	Shipping case
0200202	Scanning probe assembly, complete with 3 nozzles
T2SP-1095	Scanning probe extension, 12 ft.
T2E0-0005	NSF Scanning probe nozzle
T2E0-0572	1" Isokinetic, round (red)
T2E0-0798	Isokinetic, rectangular (blue)
6700001	Replacement line cord, 120V
5200116	¼" ID PVC sample tubing (specify length)
5500123	Filter, HEPA, 36mm (rear exhaust filter)

### Spare parts kits

2HA Spare parts kit (Recommended 1 year consumable parts):

Qty.	Item	Part Number
1	ULPA filter (internal reference air filter)	0600424
2	Pump exhaust filter (internally mounted filter)	5500002
1	Filter, HEPA, 36mm (rear exhaust filter)	5500123
<i>Replacement probe screen set, 3 pieces</i>		
1	5/16" diameter	T2SP-0883
1	1-7/16" diameter	T2SP-0884
1	31/32" diameter	T2SP-0885

2HAN Spare part kit

Qty.	Item	Part Number
2	ULPA filter (internal reference air filter)	0600424
2	Selector valve	T2G0-0931
2	Sealed cone w/ fittings*	T2GN-0949
4	Brass fittings	T2G0-0907
8	Brass fittings	5100006
25 ft	Poly-flo tubing	5200102
5 ft	PVC tubing, clear	5200116

Scanning Probe flex-probe segments

Qty.	Item	Part Number
3	Segment	5100001
1	Female threaded end segment	5100004
1	Male threaded end segment	5100002
1	Male close nipple	5100101

# Appendix C

## Contacting ATI

---

### For Technical or Application Questions

If you have any difficulty setting up the Analog Aerosol Photometer 2HA or application questions about this instrument, contact an applications engineer at ATI (410) 363-9696.

---

### For Customer Service

If the Analog Aerosol Photometer 2HA is not operating properly, or if you are returning the instrument for service, contact ATI Customer Service (410) 363-9696. Customer Service will need this information when you call:

- The instrument model number
- The instrument serial number
- A purchase order number (unless under warranty)
- A billing address
- A shipping address.

Use the original packing material to return the Analog Aerosol Photometer Model 2HA to ATI. If you no longer have the original packing material, use sufficient packing material so the instrument is not damaged during shipping.

# Appendix D

## Declaration of CE Conformity

---

We:

**AIR TECHNIQUES INTERNATIONAL**  
11403 Cronridge Drive  
Owings Mills  
Maryland 21117-2247  
USA

**Tel: (410) 363-9696**  
**Fax: (410) 363-9695**  
**Website: <http://www.air-techniques.com>**

Declare under our sole responsibility that the product,

**2HA Analog Aerosol Photometer**

is in conformity with the following directives:

Application of Council Directive(s)	Standard(s) to which Conformity is Declared
Electromagnetic Compatibility Directive (89/336/EEC)	EN 61326-1:1998
Low Voltage Directive (73/23/EEC)	EN 61010-1:2001

Design documentation is maintained at:

**Air Techniques International**  
11403 Cronridge Drive  
Owings Mills, Maryland 21117-2247  
USA

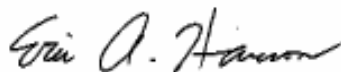

---

Eric Hanson  
President  
Air Techniques International

Date of Issue: 01 September 2004  
Place of Issue: Owings Mills,  
Maryland 21117-2247  
USA

# Appendix E

## Warranty

---

**Part Number** 1800116 / Revision C/ February 2008  
**Address** Air Techniques International / 11403 Cronridge Drive / Owings Mills, MD 21117 / USA  
**Phone No.** (410) 363-9696  
**Fax No.** (410) 363-9695  
**E-mail Address** info@atitest.com  
**Limitation of Warranty and Liability**

Air Techniques International, hereinafter referred to as ATI, warrants the equipment purchased hereunder to be free from defect in materials and workmanship under normal use and service, when used for the purpose for which it is designed, for a period of (1) one year from the date of shipment. ATI further warrants that the equipment will perform in accordance with the technical specifications accompanying the formal equipment offer.

ATI will repair or replace any such defective items that may fail within the stated warranty period, PROVIDED:

- a. That any claim of defect under this warranty is made within thirty (30) days after discovery thereof and that inspection by ATI, if required, indicates the validity of such claim to ATI's satisfaction.
- b. That the defect is not the result of damage incurred in shipment to or from our factory.
- c. That the equipment has not been altered in any way whether as to design or use, whether by replacement parts not supplied or approved by ATI, or otherwise.
- d. That any equipment or accessories furnished but not manufactured by ATI, or not of ATI design, shall be subject only to such adjustments as ATI may obtain from the supplier thereof.

ATI's obligation under this warranty is limited to the repair or replacement of defective parts with the exception noted above. If the equipment includes a scattering chamber, ATI's warranty does not extend to contamination of the scattering chamber by foreign material.

At ATI's option, any defective equipment that fails within the warranty period shall be returned to ATI's factory for inspection, properly packed with shipping charges prepaid. No equipment shall be returned to ATI without prior issuance of a return authorization by ATI.

No warranties, express or implied, other than those specifically set forth herein shall be applicable to any equipment manufactured or furnished by ATI and the foregoing warranty shall constitute the Buyer's sole right and remedy. In no event does ATI assume any liability for consequential damages, or for loss, damage or expense directly or indirectly arising from the use of ATI products, or any inability to use them either separately or in combination with other equipment or materials or from any other cause.

### Service Policy

Our service policy is designed to give prompt attention to any problems. If you encounter a defective product or discover a malfunction, please call ATI Customer Service to obtain a return authorization at (410) 363-9696.

# Appendix F

## Manual Revision History

---

### Manual Revision History

The following is a manual history of the 2H Digital Aerosol Photometer Instruction Manual, P/N 1800116

<b>Revision</b>	<b>Date</b>
C	February 2008

In Revision C, In Revision C, Manual format was revised and appendix F was added. Spare parts list and accessories was modified to change part number 5500001 to 5500123-P.



---

*Air Techniques International*  
11403 Cronridge Drive, Owings Mills, MD 21117-2247 U.S.A.  
Web: [www.air-techniques.com](http://www.air-techniques.com)

---